

# LOCKER SYSTEM

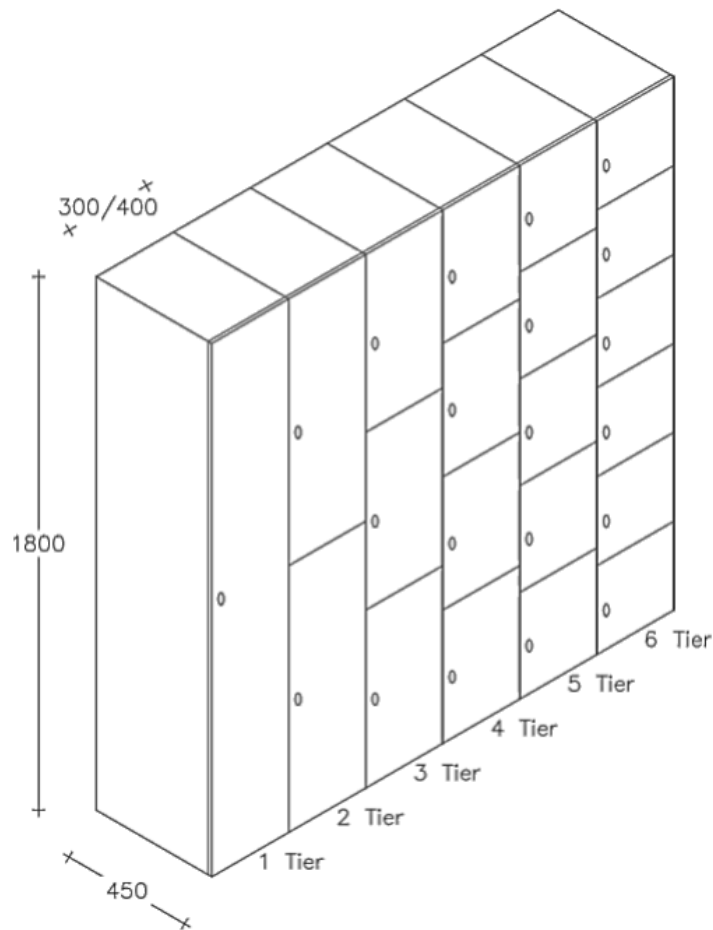

## LOCKER SYSTEM

Storage solution for dry and lighter use washroom and changing areas.



## SPECIFICATION

### Doors:

Core/Face: 10mm solid grade laminate

Edge: Polished and radiused

Colour: Refer to the Cube colour selector

Hinges: Supplied with semi concealed five-knuckle, self colour zinc plated hinges

### Carcass:

**Dry Area:** Mild steel construction with powder coated finish, supplied with coat hook to each compartment

**Wet Area:** Powder coated aluminium outer shell, supplied with coat hook to each compartment Nesting: Lockers supplied assembled as single unit

Locks: Lockers fitted with cam locks, 2 keyed and mastered as standard

Plinth: By others unless stated in quotation