

LOCKER + SYSTEM

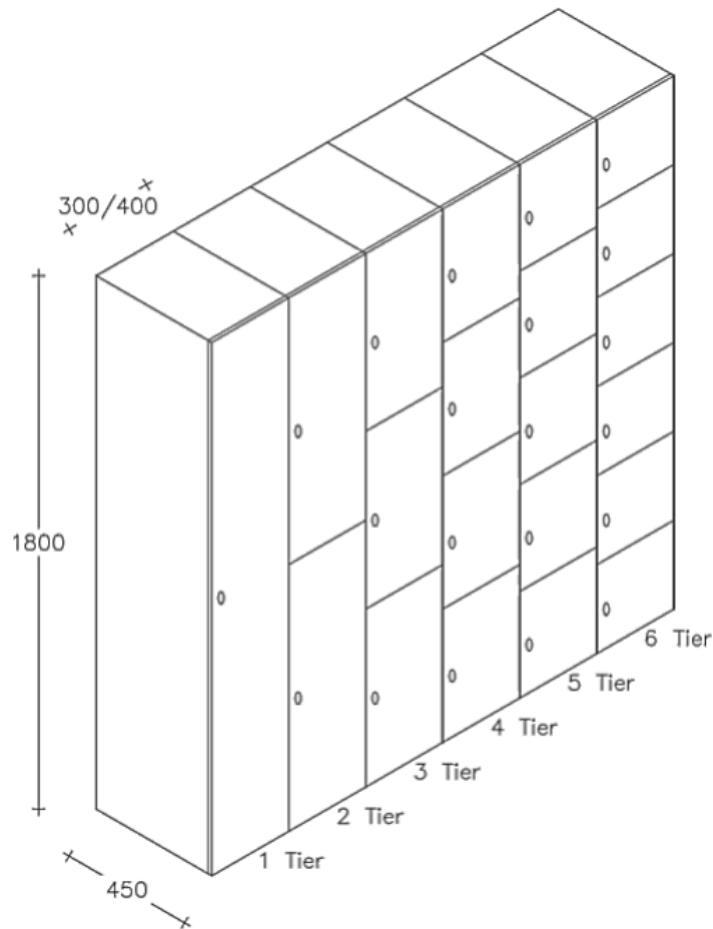

LOCKER+ SYSTEM

Storage solution for wet and high usage washroom and changing areas.



SPECIFICATION

Doors:

Core/Face: 10mm solid grade laminate

Edge: Polished and radiused

Colour: Refer to the Cube colour selector

Hinges: Supplied with semi concealed five-knuckle, self colour zinc plated hinges

Carcass:

Core/Face: 13mm solid grade laminate with shelves in 10mm solid grade laminate Nesting: Lockers supplied assembled as single units

Locks: Lockers fitted with cam locks, 2 keyed and mastered as standard

Plinth: By others unless stated in quotation

Options:

Numbering: Door numbering available as an extra

Locks: Choice of locking systems available: key operated, coin return, hasp and combination locks

Panels: Matching SGL end panels / lids available as an extra where required